

MSEB84

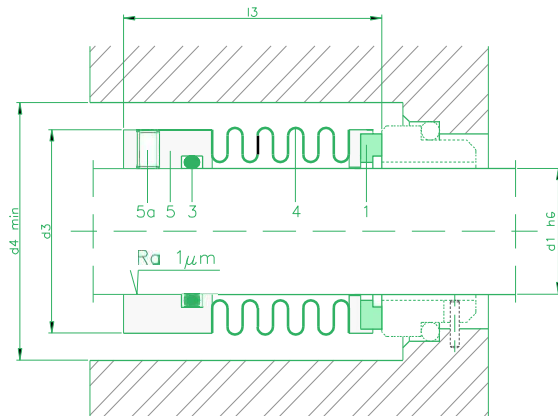

COMPONENTS:

- 1 Rotating contact surface
- 3 O-rings
- 4 Metal bellows.
- 5 Set screws
- 6 Metal frame



SECTORS:



CHARACTERISTICS:

- **Balanced.**
- Spiral-wound metal bellows.
- **Not dependent on the rotation direction.**

OPERATING LIMITS:

$d_1 = 18 \div 100 \text{ mm}$ $p = 20 \text{ kg/cm}^2$

$v = 25 \text{ m/s}$ $t = -40 \div +200 \text{ }^\circ\text{C}^{(*)}$

(*) The temperature resistance depends on the material of the secondary seals used.

The operating limits are defined by the PV factor which is determined for the sealing system characteristics and those of the application.

DESCRIPTION:

Balanced by the bellows, without the need for a stepped shaft (models MSE10B, MSE20B). Suitable for working in applications with high pressures. The O-ring resting on the shaft does not cause wear as there is no axial movement (changes in pressure). Recommended for working with sticky or viscous fluids that require cleaning processes (CIP) or sterilization processes (SIP) in situ due to the geometry of the spiral-wound bellows.

This seal may be supplied with any of the secondary parts shown in pages 56 and 57, for measurements in mm, and 58 for the measurements in inches.

DIMENSIONS CHART

Dimensions in mm

Shaft	Rotary part		
	mm	d ₃	d ₄
18	31	34	31,5
20	31	36	31,5
22	31	38	31,5
24	36	40	36,7
25	36	41	37
28	39	44	37,5
30	42	46	38
32	46	48	43
33	46	49	43
35	48,5	51	43
38	51,5	58	42
40	54	60	42
43	58,4	63	47
45	58,4	65	47
48	63,7	68	47
50	63,7	70	46,5
53	69	73	56,5
55	71	75	56,5
58	73,3	83	56,5
60	76,7	85	56,5
63	79,4	88	56,5
65	83	90	66,5
68	87,8	93	66,5
70	87,8	95	65,5
75	94	104	65,5
80	100,6	109	75
85	106	114	75
90	110,3	119	75
100	124,3	129	75

Dimensions subject to changes or modifications.

Dimensions in mm

Shaft	Rotary part			
	mm	d ₃	d ₄	l ₃
0,750	19,05	31	34,9	31,5
0,875	22,23	36	38,1	37
1,000	25,40	39	41,3	37,5
1,125	28,58	42	44,5	38
1,250	31,75	46	47,6	43
1,375	34,93	48,5	50,8	43
1,500	38,10	51,5	57,2	42
1,625	41,28	58,4	60,3	47
1,750	44,45	58,4	63,5	47
1,875	47,63	63,7	66,7	46,5
2,000	50,80	63,7	69,9	46,5
2,125	53,98	69	73	56,5
2,250	57,15	73,3	76,2	56,5
2,375	60,33	76,7	79,4	56,5
2,500	63,50	79,4	82,6	56,5
2,625	66,68	83	85,7	66,5
2,750	69,85	87,8	96	65,5
2,875	73,03	94	99	65,5
3,000	76,20	94	100	65,5
3,125	79,38	100,6	104	75
3,250	82,55	100,6	108	75
3,375	85,73	106	111	75
3,500	88,90	110,3	115	75
3,625	92,08	114,9	118	75
3,750	95,25	114,9	121	75
3,875	98,43	121,3	124	75
4,000	101,60	121,3	127	75

MSEMB86



COMPONENTS:

- 1 Rotating contact surface
- 3 Graphite wedge
- 4 Metal bellows
- 5 Metal frame
- 5a Set screws
- 5b Tightening screw

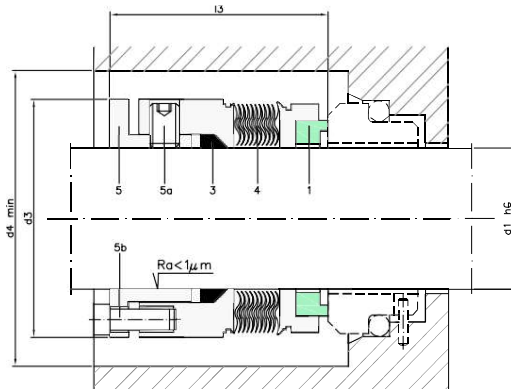

SECTORS:



CHARACTERISTICS:

- **Balanced.**
- Graphite wedge
- **Welded metal bellows.**
- Not dependent on the rotation direction.

OPERATING LIMITS:

$d_1 = 25 \div 100 \text{ mm}$ $p = 20 \text{ kg/cm}^2$
 $v = 25 \text{ m/s}$ $t = -75 \div -425 \text{ oC}^{(*)}$

(*) The temperature resistance depends on the material of the secondary seals used.

The operating limits are defined by the PV factor which is determined for the sealing system characteristics and those of the application.

DESCRIPTION :

Internally balanced, with no need for a stepped shaft (models MSEWS10B, MSEMS20B). The graphite wedge allows applications at very high temperatures. Appropriate for applications with sticky or high viscosity fluids as its open leaf design generates a self-cleaning effect. In addition it is suitable for application at moderate pressures as well as with very aggressive fluids, both chemically and mechanically terms. Very often used in compressors.

This seal may be supplied with any of the stationary parts shown in pages 56 and 57, for measurements in mm, and 58 for the measurements in inches.

DIMENSIONS CHART

Dimensions in mm

Shaft	Rotary part		
	mm	d ₃	d ₄
25	41,28	46,28	38,89
28	44,45	49,45	39,67
32	47,63	52,63	40,46
35	50,80	55,80	40,46
38	53,98	58,98	40,46
40	57,15	62,15	40,46
45	60,33	65,33	41,28
48	63,50	68,50	41,28
50	66,68	71,68	42,06
55	69,85	74,85	42,06
60	76,20	81,20	43,66
65	82,55	87,55	44,45
70	88,90	93,90	45,24
75	96,82	101,82	47,63
80	101,60	106,60	47,63
85	107,95	112,95	47,63
90	111,13	116,13	47,63
95	117,48	122,48	47,63
100	123,83	128,83	47,63

Dimensions subject to changes or modifications.

Dimensions in inches

Shaft	Rotary part			
	(")	mm	d ₃	d ₄
1,000	25,40	41,28	46,28	38,89
1,125	28,58	44,45	49,45	39,67
1,250	31,75	47,63	52,63	40,46
1,375	34,93	50,80	55,80	40,46
1,500	38,10	53,98	58,98	40,46
1,625	41,28	57,15	62,15	40,46
1,750	44,45	60,33	65,33	41,28
1,875	47,63	63,50	68,50	41,28
2,000	50,80	66,68	71,68	42,06
2,125	53,98	69,85	74,85	42,06
2,250	57,15	73,03	78,03	43,66
2,375	60,33	76,20	81,20	43,66
2,500	63,50	82,55	87,55	44,45
2,625	66,68	85,73	90,73	45,24
2,750	69,85	88,90	93,90	45,24
2,875	73,03	93,65	98,65	47,63
3,000	76,20	96,82	101,82	47,63
3,125	79,38	101,60	106,60	47,63
3,250	82,55	104,78	109,78	47,63
3,375	85,73	107,95	112,95	47,63
3,500	88,90	111,13	116,13	47,63
3,625	92,08	114,30	119,30	47,63
3,750	95,25	117,48	122,48	47,63
3,875	98,43	120,65	125,65	47,63
4,000	101,60	123,83	128,83	47,63

MSERB00



COMPONENTS:

- 1 Rotating contact surface
- 2 Stationary contact surface
- 3 Bellows
- 3a Elastomeric cup
- 4 Spring
- 5 Ring
- 5a Drive ring
- 5b Metal frame

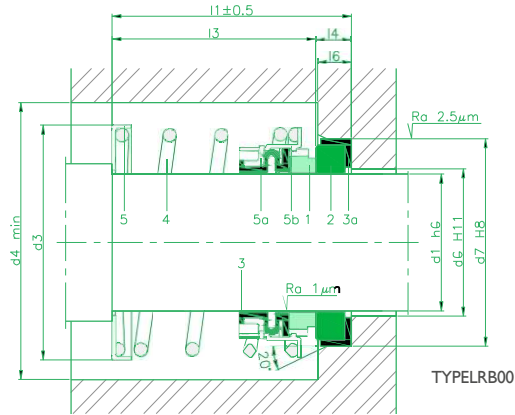

SECTORS:



CHARACTERISTICS:

- **Balanced.**
- Not dependent on the rotation direction.
- **Single cylindrical spring.**

OPERATING LIMITS:

$d_1 = 9.52 \div 101.60 \text{ mm}$ $p = 14 \text{ kg/cm}^2$

$v = 13 \text{ m/s}$ $t = -20 \div +200 \text{ }^\circ\text{C}^{(*)}$

(*) The temperature resistance depends on the material of the secondary seals used.

The operating limits are defined by the PV factor which is determined for the sealing system characteristics and those of the application.

DESCRIPTION:

Mechanical seal with a simple, compact design for all-purpose use and in particular in applications with moderate pressures (up to 14 kg/cm²) such as pumps and compressors.

DIMENSIONS CHART B00

Dimensions in inches

Shaft (")	Rotary part			Stationary part				Total length	
	mm	d ₃	d ₄	l ₃	d ₆	d ₇	l ₄	l ₅	
3/8	9.52	28	32	25	11.0	24.6	8.7	7.1	33.7
1/2	12.70	32	36	25	13.5	27.8	8.7	7.1	33.7
5/8	15.88	35	39	25	17.0	30.9	10.5	8.7	35.5
3/4	19.05	40	44	25	20.0	34.1	10.5	8.7	35.5
13/16	20.63	41	45	25	22.0	35.7	10.5	8.7	35.5
7/8	22.22	43	47	25	23.0	37.3	10.5	8.7	35.5
1	25.40	47	51	25	26.5	40.5	10.5	8.7	35.5
1 1/8	28.57	56	60	33	29.5	47.6	12.0	10.3	45.0
1 1/4	31.75	59	63	33	32.5	50.8	12.0	10.3	45.0
1 3/8	34.92	63	67	33	36.5	54.0	12.0	10.3	45.0
1 1/2	38.10	67	71	33	39.5	57.1	12.0	10.3	45.0
1 5/8	41.27	71	75	33	42.5	60.3	12.0	10.3	45.0
1 3/4	44.45	74	78	41	46.0	63.5	12.0	10.3	53.0
1 7/8	47.62	77	81	41	49.0	66.7	12.0	10.3	53.0
2	50.80	81	85	41	52.0	69.8	13.5	12.0	54.5
2 1/8	53.97	84	88	41	55.5	73.1	13.5	12.0	54.5
2 1/4	57.15	88	92	41	58.5	76.2	13.5	12.0	54.5
2 3/8	60.32	91	95	41	61.5	79.4	13.5	12.0	54.5
2 1/2	63.50	94	98	41	65.0	82.5	13.5	12.0	54.5
2 5/8	66.67	100	104	49	68.0	92.1	16.0	14.3	65.0
2 3/4	69.85	103	107	49	71.0	95.2	16.0	14.3	65.0
2 7/8	73.02	108	112	52	74.5	98.4	16.0	14.3	68.0
3	76.20	111	115	52	77.5	101.6	16.0	14.3	68.0
3 1/8	79.37	118	122	56	80.5	111.1	20.0	18.3	76.0
3 1/4	82.55	121	125	56	84.0	114.3	20.0	18.3	76.0
3 3/8	85.72	125	129	56	87.0	117.5	20.0	18.3	76.0
3 1/2	88.90	128	132	56	90.5	120.6	20.0	18.3	76.0
3 5/8	92.07	131	135	59	93.5	123.8	20.0	18.3	79.0
3 3/4	95.25	134	138	59	96.5	127.0	20.0	18.3	79.0
3 7/8	98.42	139	143	62	100.0	130.2	20.0	18.3	82.0
4	101.60	142	146	62	103.0	133.3	20.0	18.3	82.0

Dimensions subject to changes or modifications.

MSERB00U and MSERB00L



COMPONENTS:

- 1 Rotating contact surface
- 2 Stationary contact surface
- 3 Bellows
- 3a Elastomeric cup
- 4 Spring
- 5 Ring
- 5a Drive ring
- 5b Metal frame

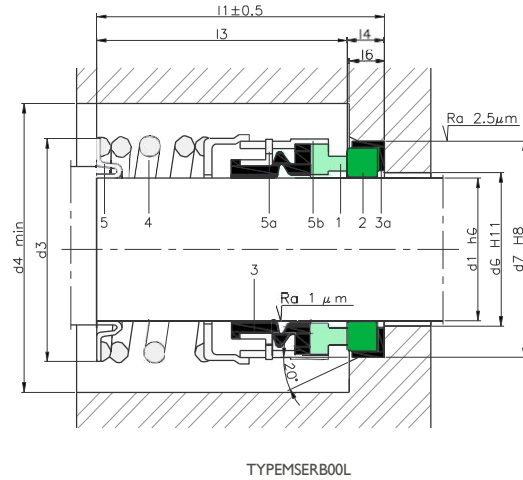
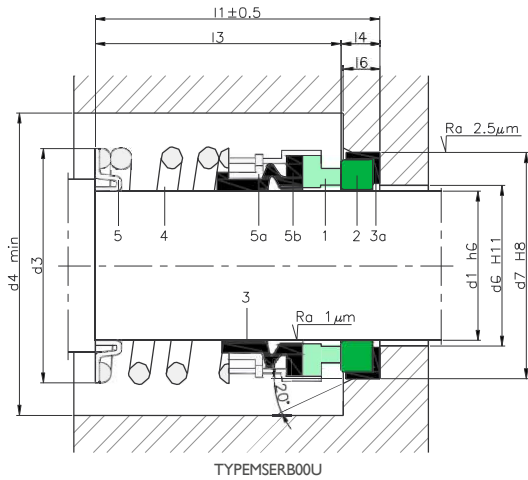

DIMENSIONS CHART MSERB00U
Dimensions in inches

	Shaft		Rotary part			Stationary part				Total length
	(")	mm	d ₃	d ₄	l ₃	d ₆	d ₇	l ₄	l ₆	l ₁
5/8	15.88	27.8	31.8	33.3	23.80	31.75	10.3	8.7		43.6
3/4	19.05	30.9	34.9	33.3	26.98	34.93	10.3	8.7		43.6
7/8	22.23	34.1	38.1	33.3	30.15	38.10	10.3	8.7		43.6
1	25.40	38.1	42.1	39.7	33.32	41.28	11.1	9.5		50.8
1 1/8	28.58	41.3	45.3	41.3	36.50	44.44	11.1	9.5		52.4
1 1/4	31.75	46.0	50.0	41.3	39.70	47.63	11.1	9.5		52.4
1 3/8	34.93	47.6	51.6	42.9	42.84	50.80	11.1	9.5		54.0
1 1/2	38.10	50.8	54.8	42.9	46.05	53.98	11.1	9.5		54.0
1 5/8	41.28	57.2	61.2	50.8	50.80	60.33	12.7	11.1		63.5
1 3/4	44.45	60.4	64.4	50.8	53.97	63.50	12.7	11.1		63.5
2	50.80	66.7	70.7	54.0	60.32	69.85	12.7	11.1		66.7
2 1/4	57.15	74.6	78.6	60.3	61.90	79.38	14.2	12.7		74.5
2 1/2	63.50	81.0	85.0	63.5	68.25	85.73	14.2	12.7		77.7
2 3/4	69.85	88.9	92.9	69.9	74.60	88.90	15.8	14.5		85.7
2 7/8	73.03	92.1	96.1	73.0	77.77	95.25	15.8	14.5		88.8
3	76.20	95.3	99.3	73.0	80.95	98.43	15.8	14.5		88.8
3 1/8	79.38	101.6	105.6	79.4	84.12	101.60	19.8	16.6		99.2
3 1/4	82.55	104.8	108.8	79.4	87.30	104.78	19.8	16.6		99.2
3 3/8	85.73	108.0	112.0	79.4	90.47	107.95	19.8	16.6		99.2
3 1/2	88.90	111.1	115.1	79.4	93.65	111.13	19.8	16.6		99.2
3 5/8	92.08	114.3	118.3	82.6	96.82	114.30	19.8	16.6		102.4
3 3/4	95.25	117.7	121.7	82.6	100.00	117.48	19.8	16.6		102.4
3 7/8	98.43	120.7	124.7	85.7	103.17	120.65	19.8	16.6		105.5
4	101.60	123.8	127.8	85.7	106.35	123.85	19.8	16.6		105.5

Dimensions subject to changes or modifications.

DIMENSIONS CHART MSERB00L
Dimensions in inches

	Shaft		Rotary part			Stationary part				Total length
	(")	mm	d ₃	d ₄	l ₃	d ₆	d ₇	l ₄	l ₆	l ₁
5/8	15.88	27.8	31.8	44	17.0	30.9	10.5	8.7		54.5
3/4	19.05	30.9	34.9	44	20.0	34.1	10.5	8.7		54.5
7/8	22.23	34.1	38.1	44	23.0	37.3	10.5	8.7		54.5
1	25.40	38.1	42.1	44	26.5	40.5	10.5	8.7		54.5
1 1/8	28.58	41.3	45.3	60	29.5	47.6	12.0	10.3		72.0
1 1/4	31.75	46.0	50.0	60	32.5	50.8	12.0	10.3		72.0
1 3/8	34.93	47.6	51.6	60	36.5	54.0	12.0	10.3		72.0
1 1/2	38.10	50.8	54.8	60	39.5	57.1	12.0	10.3		72.0
1 5/8	41.28	57.2	61.2	60	42.5	60.3	12.0	10.3		72.0
1 3/4	44.45	60.4	64.4	71	46.0	63.5	12.0	10.3		83.0
1 7/8	47.63	63.5	67.5	71	49.0	66.7	12.0	10.3		83.0
2	50.80	66.7	70.7	71	52.0	69.8	13.5	12.0		84.5
2 1/8	53.98	71.4	75.4	71	55.5	73.1	13.5	12.0		84.5
2 1/4	57.15	74.6	78.6	71	58.5	76.2	13.5	12.0		84.5
2 3/8	60.33	78.3	82.3	71	61.5	79.4	13.5	12.0		84.5
2 1/2	63.50	81.0	85.0	71	65.0	82.5	13.5	12.0		84.5
2 5/8	66.68	85.7	89.7	70	68.0	85.7	16.0	14.3		86.0
2 3/4	69.85	88.9	92.9	70	71.0	88.9	16.0	14.3		86.0
2 7/8	73.03	92.1	96.1	73	74.5	92.1	16.0	14.3		89.0
3	76.20	95.3	99.3	73	77.5	95.3	16.0	14.3		89.0
3 1/8	79.38	101.6	105.6	79	80.5	101.6	20.0	18.3		99.0
3 1/4	82.55	104.8	108.8	79	84.0	104.8	20.0	18.3		99.0
3 3/8	85.73	108.0	112.0	79	87.0	108.0	20.0	18.3		99.0
3 1/2	88.90	111.1	115.1	79	90.5	111.1	20.0	18.3		99.0
3 5/8	92.08	114.3	118.3	83	93.5	114.3	20.0	18.3		103.0
3 3/4	95.25	117.7	121.7	83	96.5	117.7	20.0	18.3		103.0
3 7/8	98.43	120.7	124.7	86	100.0	120.7	20.0	18.3		106.0
4	101.60	123.8	127.8	86	103.0	123.8	20.0	18.3		106.0

Dimensions subject to changes or modifications.

MSEB01-MSEB01S -MSEB04 - MSEB04A and MSEB06



COMPONENTS:

- 1 Rotating contact surface
- 2 Stationary contact surface
- 3 Bellows
- 3a Elastomeric cup
- 4 Spring
- 5 Ring
- 5a Drive ring
- 5b Metal frame

SECTORS:



CHARACTERISTICS:

- Unbalanced.
- Not dependent on the rotation direction.
- Single cylindrical spring.

OPERATING LIMITS:

$d_f = 9.52 \div 101.60 \text{ mm } \rho = 10 \text{ kg/cm}^2$

$v = 10 \text{ m/s}$

$t = -15 \div +200\text{C}^{(*)}$

(*) The temperature resistance depends on the material of the secondary seals used.

The operating limits are defined by the PV factor which is determined for the sealing system characteristics and those of the application.

DESCRIPTION:

Mechanical seal with a simple design for general use. Type MSEB04/ MSEB04A are standardised models in accordance with EN 12756 (KU).

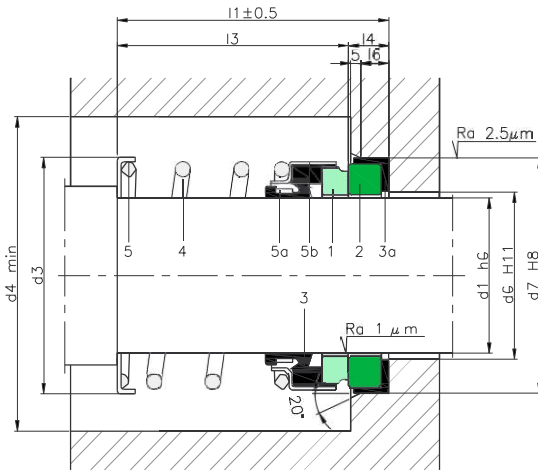

DIMENSIONS CHARRB01

Dimensions in inches

Shaft (")	Rotary part					Stationary part					Total length l ₁
	mm	d ₃	d ₄	l ₃	d ₆	d ₇	l ₄	l ₅	l ₆		
3/8	9.52	23.80	28.80	22.20	15.90	22.22	6.3	1.3	5.1	28.50	
1/2	12.70	23.80	28.80	20.60	19.05	25.40	8.0	1.3	5.1	28.60	
5/8	15.88	26.50	31.50	22.20	22.20	31.75	10.3	1.3	7.5	32.50	
3/4	19.05	30.50	35.50	22.20	25.40	34.93	10.3	1.3	7.5	32.50	
7/8	22.20	34.00	39.50	24.00	28.60	38.10	10.3	1.3	7.5	34.30	
1	25.40	40.00	45.00	25.40	31.80	41.28	11.0	1.3	8.3	36.40	
1 1/8	28.60	44.50	49.50	27.00	35.70	44.45	11.0	1.3	8.3	38.00	
1 1/4	31.75	46.50	52.00	27.00	38.90	47.66	11.0	1.3	8.3	38.00	
1 3/8	34.92	51.50	56.50	28.50	42.10	50.80	11.0	1.3	8.3	39.50	
1 1/2	38.10	54.00	60.00	28.50	45.20	54.00	11.0	1.3	8.3	39.50	
1 5/8	41.27	58.00	63.00	35.00	48.80	60.30	12.7	1.3	9.8	47.70	
1 3/4	44.45	61.50	66.50	35.00	51.60	63.50	12.7	1.3	9.8	47.70	
1 7/8	47.62	65.50	70.50	38.00	54.80	66.65	12.7	1.3	9.8	50.70	
2	50.80	70.50	75.50	38.00	58.00	69.85	12.7	1.3	9.8	50.70	
2 1/8	53.97	75.00	80.00	43.00	62.00	76.20	14.3	1.3	11.4	57.30	
2 1/4	57.15	79.00	84.00	43.00	65.00	79.40	14.3	1.3	11.4	57.30	
2 3/8	60.32	82.00	87.00	46.00	68.00	82.55	14.3	1.3	11.4	60.30	
2 1/2	63.50	87.00	92.00	46.00	71.20	85.70	14.3	1.3	11.4	60.30	
2 5/8	66.68	88.00	96.50	49.20	71.00	85.70	15.9	1.3	13.2	65.10	
2 3/4	69.85	90.00	98.00	49.20	74.60	88.90	15.9	1.3	13.2	65.10	
2 7/8	73.03	95.00	104.00	52.40	77.80	95.25	15.9	1.3	13.2	68.30	
3	76.20	99.00	104.00	52.40	81.00	98.43	15.9	1.3	13.2	68.30	
3 1/8	79.38	104.00	109.00	55.50	80.10	101.60	19.8	1.3	15.4	74.90	
3 1/4	82.55	109.00	114.00	55.50	87.30	104.78	19.8	1.3	15.4	74.90	
3 3/8	85.73	109.00	114.00	55.50	90.50	107.95	19.8	1.3	15.4	74.90	
3 1/2	88.90	114.00	119.00	55.50	93.60	111.13	19.8	1.3	15.4	74.90	
3 5/8	92.08	119.00	124.00	58.70	96.80	114.30	19.8	1.3	15.4	78.50	
3 3/4	95.25	119.00	124.00	58.70	100.00	117.48	19.8	1.3	15.4	78.50	
3 7/4	98.43	124.00	129.00	61.90	103.10	120.65	19.8	1.3	15.4	81.70	
4	101.60	124.00	129.00	61.90	106.30	123.83	19.8	1.3	15.4	81.70	

Dimensions subject to changes or modifications.

DIMENSIONS CHARRB01S

Dimensions in inches

Shaft (")	Rotary part				Stationary part						Total length l ₁
	mm	d ₃	d ₄	l ₃	d ₆	d ₇	l ₄	l ₅	l ₆		
3/8	9.52	22	27	25.4	16	24.6	8.7	1.3	6.2	34.1	
1/2	12.70	26	31	25.4	19	27.8	8.7	1.3	6.2	34.1	
5/8	15.88	32	37	25.4	22	30.9	10.3	1.3	9.0	35.7	
3/4	19.05	36	41	25.4	25	34.1	10.3	1.3	9.0	35.7	
7/8	22.20	39	44	25.4	28	37.3	10.3	1.3	9.0	35.7	
1	25.40	42	47	25.4	32	40.5	10.3	1.3	9.0	35.7	
1 1/8	28.60	46	51	33.3	36	47.6	12.0	1.3	9.2	45.5	
1 1/4	31.75	49	54	33.3	39	50.8	12.0	1.3	9.2	45.5	
1 3/8	34.92	54	59	33.3	42	53.9	12.0	1.3	9.2	45.5	
1 1/2	38.10	59	64	33.3	45	57.1	12.0	1.3	9.2	45.5	
1 5/8	41.27	61	66	33.3	48	60.3	12.0	1.3	9.2	45.5	
1 3/4	44.45	64	69	40.5	52	63.5	12.0	1.3	9.2	52.5	
1 7/8	47.62	66	71	40.5	55	66.7	12.0	1.3	9.2	52.5	
2	50.80	69	74	40.5	58	69.8	13.5	1.3	10.7	54.0	
2 1/8	53.97	78	83	41.0	62	73.1	13.5	1.3	10.7	54.5	
2 1/4	57.15	80	85	41.0	65	76.2	13.5	1.3	10.7	54.5	
2 3/8	60.32	83	88	41.0	68	79.4	13.5	1.3	10.7	54.5	
2 1/2	63.50	85	90	41.0	71	82.5	13.5	1.3	10.7	54.5	
2 5/8	66.68	90	95	49.0	78	92.1	15.9	1.3	13.2	64.9	
2 3/4	69.85	95	100	49.0	81	95.2	15.9	1.3	13.2	64.9	
2 7/8	73.03	99	104	49.0	84	98.4	15.9	1.3	13.2	64.9	
3	76.20	99	104	49.0	88	101.6	15.9	1.3	13.2	64.9	
3 1/8	79.38	104	109	56.0	94	111.1	20.0	1.3	17.2	76.0	
3 1/4	82.55	109	114	56.0	97	114.3	20.0	1.3	17.2	76.0	
3 3/8	85.73	109	114	56.0	100	117.5	20.0	1.3	17.2	76.0	
3 1/2	88.90	114	119	56.0	103	120.6	20.0	1.3	17.2	76.0	
3 5/8	92.08	119	124	59.0	106	123.8	20.0	1.3	17.2	79.0	
3 3/4	95.25	119	124	59.0	109	127.0	20.0	1.3	17.2	79.0	
3 7/4	98.43	124	129	62.0	113	130.2	20.0	1.3	17.2	82.0	
4	101.60	124	129	62.0	116	133.3	20.0	1.3	17.2	82.0	

Dimensions subject to changes or modifications.

DIMENSIONS CHART MSERB04 / MSERB04A

Dimensions in mm

Shaft mm	Rotary part				Stationary part						Total length mm
	d ₃	d ₄	l ₃	l _{3A}	d ₆	d ₇	l ₄	l _{4A}	l ₅	l ₆	
10	20	25	23.9		17	21	8.6		1.5	4	32.5
12	22	27	23.9	26	19	23	8.6	6.5	1.5	4	32.5
14	24	29	26.4		21	25	8.6		1.5	4	35.0
16	26	31.5	26.4	24.7	23	27	8.6	10.3	1.5	4	35.0
18	32	37	27.5		27	33	10.0		2.0	4	37.5
20	34	39.5	27.5		29	35	10.0		2.0	5	37.5
22	36	41	27.5	26.5	31	37	10.0	11	2.0	5	37.5
24	38	45	30.0	29.0	33	39	10.0	11	2.0	5	40.0
25	39	45	30.0	29.0	34	40	10.0	11	2.0	5	40.0
28	42	49.5	32.5	31.5	37	43	10.0	11	2.0	5	42.5
30	44	52	32.5	31.5	39	45	10.0	11	2.0	5	42.5
32	46	52	32.5	31.5	42	48	10.0	11	2.0	5	42.5
33	47	55.5	32.5	31.5	42	48	10.0	11	2.0	5	42.5
35	49	56.5	32.5	31.5	44	50	10.0	11	2.0	5	42.5
38	54	60	34.0		49	56	11.0		2.0	6	45.0
40	56	63	34.0	32.3	51	58	11.0	12.7	2.0	6	45.0
43	59	66.5	34.0	32.3	54	61	11.0	12.7	2.0	6	45.0
45	61	66.5	34.0	32.3	56	63	11.0	12.7	2.0	6	45.0
48	64	70.5	34.0	32.3	59	66	11.0	12.7	2.0	6	45.0
50	66	75	34.5	34.8	62	70	13.0	12.7	2.5	6	47.5
53	69	79	34.5	33.2	65	73	13.0	14.3	2.5	6	47.5
55	71	81	34.5	33.2	67	75	13.0	14.3	2.5	6	47.5
58	78	84	39.5	38.2	70	78	13.0	14.3	2.5	6	52.5
60	80	87	39.5	38.2	72	80	13.0	14.3	2.5	6	52.5
63	83	91	39.5	38.2	75	83	13.0	14.3	2.5	6	52.5
65	85	92	39.5	36.5	77	85	13.0	16	2.5	6	52.5
68	88	96.5	37.2	36.5	81	90	15.3	16	2.5	7	52.5
70	90	98	44.7	44.0	83	92	15.3	16	2.5	7	60.0
75	99	104	44.7		88	97	15.3		2.5	7	60.0
80	104	109	44.3		95	105	15.7		3.0	7	60.0
85	109	114	44.3		100	110	15.7		3.0	7	60.0
90	114	119	49.3		105	115	15.7		3.0	7	65.0
95	119	124	49.3		110	120	15.7		3.0	7	65.0
100	124	129	49.3		115	125	15.7		3.0	7	65.0

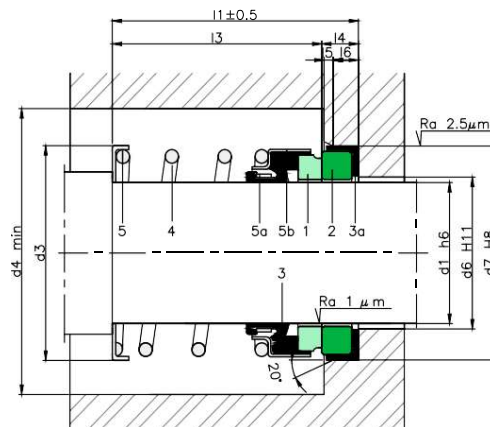

Dimensions subject to changes or modifications.

DIMENSIONS CHART MSERB06

Dimensions in mm

Shaft mm	Rotary part			Stationary part					Total length mm
	d ₃	d ₄	l ₃	d ₆	d ₇	l ₄	l ₅	l ₆	
10	20	25	25.4	16.0	24.6	8.7	1.5	7.5	34.1
12	22	27	25.4	19.0	27.8	8.7	1.5	7.5	34.1
13	24	29	25.4	19.0	27.8	8.7	1.5	7.5	34.1
14	24	29	25.4	22.2	30.9	10.3	1.5	7.5	34.1
15	26	31	25.4	22.2	30.9	10.3	1.5	7.5	35.7
16	26	31	25.4	22.2	30.9	10.3	1.5	7.5	34.1
18	32	37	25.4	25.4	34.1	10.3	1.5	7.5	34.1
19	34	39	25.4	25.4	34.1	10.3	1.5	7.5	34.1
20	34	39	25.4	27.0	35.7	10.3	1.5	7.5	35.7
22	36	41	25.4	28.6	37.3	10.3	1.5	7.5	34.1
24	38	43	25.4	31.7	40.5	10.3	1.5	7.5	34.1
25	39	44	25.4	31.7	40.5	10.3	1.5	7.5	35.7
28	42	47	33.3	35.7	47.6	12.0	2.0	8.5	45.3
30	44	49	33.3	38.9	50.8	12.0	2.0	8.5	45.3
32	46	51	33.3	38.9	50.8	12.0	2.0	8.5	45.3
33	47	52	33.3	42.1	54.0	12.0	2.0	8.5	45.3
34	49	54	33.3	42.1	54.0	12.0	2.0	8.5	45.3
35	49	54	33.3	42.1	54.0	12.0	2.0	8.5	45.3
38	54	59	33.3	45.2	57.2	12.0	2.0	8.5	45.3
40	56	61	33.3	48.8	60.3	12.0	2.0	8.5	45.3
42	59	64	40.5	51.6	63.5	12.0	2.0	8.5	52.5
43	59	64	40.5	51.6	63.5	12.0	2.0	8.5	52.5
44	61	66	40.5	51.6	63.5	12.0	2.0	8.5	52.5
45	61	66	40.5	51.6	63.5	12.0	2.0	8.5	52.5
48	64	69	40.5	54.8	66.7	12.0	2.0	8.5	52.5
50	66	71	40.5	58.0	69.8	12.0	2.0	8.5	52.5
53	69	74	41.0	62.0	73.0	13.5	2.0	10.0	54.5
55	71	76	41.0	65.0	76.2	13.5	2.0	10.0	54.5
58	78	83	41.0	68.0	79.4	13.5	2.0	10.0	54.5
60	80	85	41.0	68.0	79.4	13.5	2.0	10.0	54.5
63	83	88	41.0	71.2	82.5	13.5	2.0	10.0	54.5
65	85	90	49.0	78.3	92.1	15.9	2.0	12.0	64.9
70	90	95	49.0	81.1	95.5	15.9	2.0	12.0	64.9
75	99	104	49.0	88.1	101.6	15.9	2.0	12.0	64.9
80	104	109	56.0	97.0	114.3	20.0	2.0	16.5	76.0
85	109	114	56.0	100.0	117.5	20.0	2.0	16.5	76.0
90	114	119	59.0	107.0	123.8	20.0	2.0	16.5	79.0
95	119	124	59.0	110.0	127.0	20.0	2.0	16.5	79.0
100	124	129	62.0	116.0	133.3	20.0	2.0	16.5	82.0

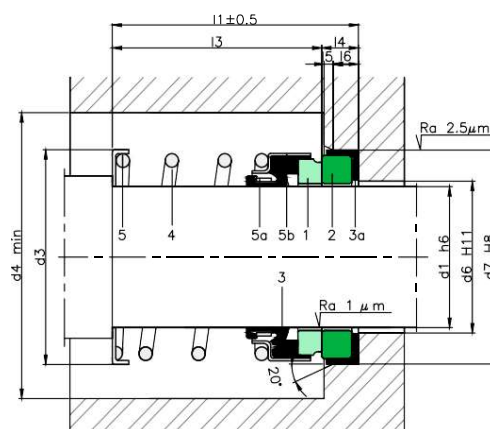

Dimensions subject to changes or modifications.

MSERB02



COMPONENTS:

- 1 Rotating contact surface
- 2 Stationary contact surface
- 3 Bellows
- 3a Elastomeric cup
- 4 Spring
- 5 Metal frame

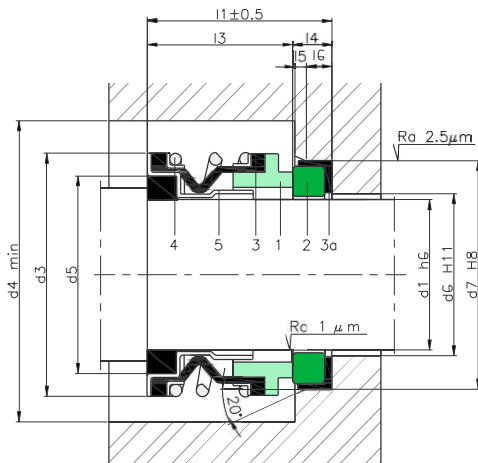

SECTORS:



CHARACTERISTICS:

- Unbalanced.
- Not dependent on the rotation direction.
- Single cylindrical spring.

OPERATING LIMITS:

$d_1 = 9.52 \div 25.40 \text{ mm}$ $p = 7 \text{ kg/cm}^2$

$v = 10 \text{ m/s}$ $t = -15 \div +200 \text{ }^\circ\text{C}^{(*)}$

(*) The temperature resistance depends on the material of the secondary seals used.

The operating limits are defined by the PV factor which is determined for the sealing system characteristics and those of the application.

DESCRIPTION:

Seal with a compact design for applications with low demands that require small diameters and often used for water pumps.

DIMENSIONS CHART

Dimensions in inches

Shaft		Rotary part					Stationary part					Total length
(")	mm	d ₃	d ₄	d ₅	l ₃	d ₆	d ₇	l ₄	l ₅	l ₆	l ₁	
3/8	9.52	23.80	28.80	17.46	16.00	14.3	22.22	6.2	1.3	5.1	22.2	
1/2	12.70	26.97	31.97	20.63	18.30	17.5	25.40	8.0	1.3	5.1	26.3	
5/8	15.88	30.94	35.94	23.81	18.70	20.6	31.75	10.3	1.3	7.5	29.0	
3/4	19.05	34.11	39.11	26.98	18.70	23.8	34.93	10.3	1.3	7.5	29.0	
1	25.40	42.85	47.85	33.33	20.60	30.2	41.28	11.0	1.3	7.5	31.6	

Dimensions subject to changes or modifications.

MSERB03 - MSERB03A - MSERB03B



TYPE LRB03

COMPONENTS:

- 1 Rotating contact surface
- 2 Stationary contact surface
- 3 Bellows
- 3a Elastomeric cup
- 4 Spring
- 5 Metal frame

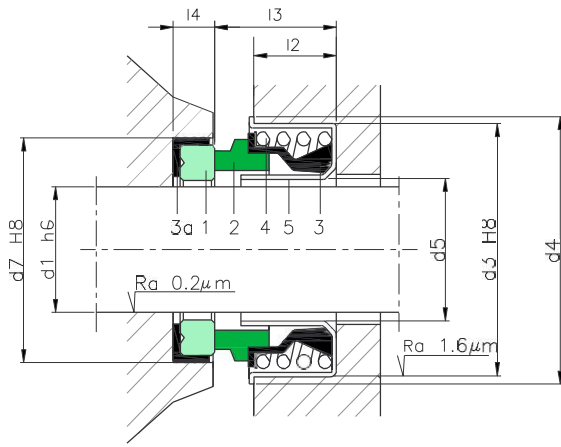

SECTORS:



CHARACTERISTICS:

- Unbalanced.
- Not dependent on the rotation direction.
- Single cylindrical spring.

OPERATING LIMITS:

$d_1 = 10 \div 30 \text{ mm}$ $p = 6 \text{ kg/cm}^2$

$v = 10 \text{ m/s}$ $t = -20 \div +100 \text{ }^\circ\text{C}^{(*)}$

(*) The temperature resistance depends on the material of the secondary seals used.

The operating limits are defined by the PV factor which is determined for the sealing system characteristics and those of the application.

DESCRIPTION:

Mechanical seal with a compact design and small dimensions which is ideal for simple hydromassage or drinking water pumps.

The rotating part is attached to the pump impeller, rotates together with it. The stationary part is secured to the housing on its external diameter.

DIMENSIONS CHART

Dimensions in mm

	Shaft		Rotary part		Stationary part			
	(")	mm	d ₇	l ₄	d ₃	d ₄	d ₅	l ₂
1/2	13	25.0	7.5	28.5	32.0	14.5	8.0	13.2
1/2 B	13	25.0	5.0	28.5	32.0	14.5	8.0	13.2
1/2 C	13	25.0	5.0	30.0	34.5	14.0	7.5	13.2
5/8	16	31.7	10.0	36.5	41.0	17.5	8.5	16.3
5/8 B	16	31.0	5.0	36.5	41.0	17.5	8.5	16.3
3/4	19	35.0	10.0	40.0	43.0	21.5	9.5	16.0
3/4 B	19	35.0	5.0	40.0	43.0	21.5	9.5	16.0
1	25	41.0	11.0	47.0	51.0	26.5	11.0	18.0
1 1/8	29	48.0	8.5	52.0	57.0	31.0	11.0	18.5

Dimensions subject to changes or modifications.

MSERB03A



TYPE LRB03A

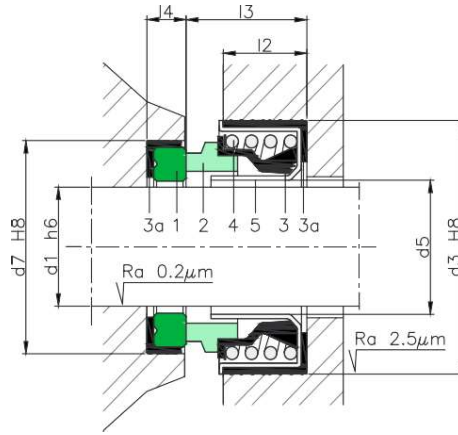

DIMENSIONS CHART MSERB03A

Dimensions in mm

Shaft mm	Rotary part		Stationary part			
	d_7	l_4	d_3	d_5	l_2	l_3
10	23.0	4	27	11.0	7.5	14.0
12	25.0	5	32	14.2	8.5	14.2
16	31.0	5	41	18.2	10.0	16.8
20	35.0	5	45	21.4	10.0	17.5
25	41.3	11	52	26.4	11.5	20.0
30	48.0	8	58	31.0	12.5	21.0

Dimensions subject to changes or modifications.

MSERB03B



TYPE LRB03B

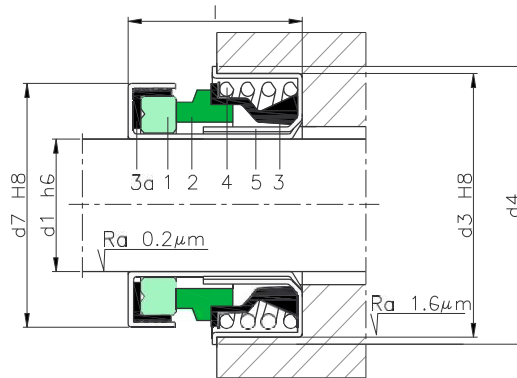

DIMENSIONS CHART MSERB03B

Dimensions in mm

Shaft mm	d_3	d_4	d_7	l
12	12.0	30.00	35.0	25.0
12 B	12.0	28.55	32.0	25.0
12 C	12.0	33.40	38.0	25.0
13	13.0	30.00	35.0	25.0
15	15.0	36.50	41.5	30.0
16	16.0	36.50	41.5	30.0
16 B	16.0	38.10	41.3	28.5
20	20.0	40.00	43.7	37.0
20 B	20.0	38.00	43.7	37.0

Dimensions subject to changes or modifications.

MSERB05



COMPONENTS:

- 1 Rotating contact surface
- 2 Stationary contact surface
- 3 Bellows
- 3a Elastomeric cup
- 4 Spring
- 5 Ring
- 5a Drive ring
- 5b Metal frame

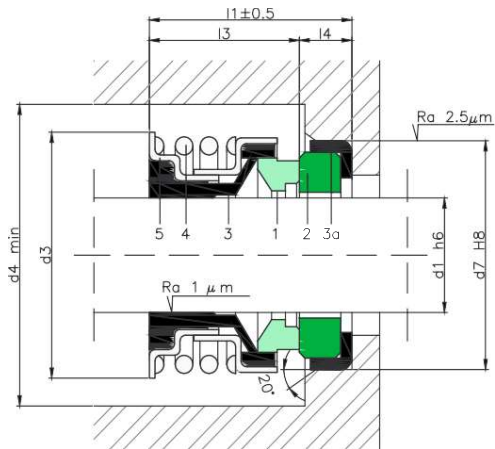

SECTORS:



CHARACTERIST: ICS

- Unbalanced.
- Not dependent on the rotation direction.
- Single cylindrical spring.

OPERATING LIMITS:

$$d_1 = 12 \div 25.4 \text{ mm} \quad p = 7 \text{ kg/cm}^2$$

$$v = 10 \text{ m/s} \quad t = -20 \div +100^\circ\text{C} \text{ (*)}$$

(*) The temperature resistance depends on the material of the secondary seals used.

The operating limits are defined by the PV factor which is determined for the sealing system characteristics and those of the application.

DESCRIPCIÓN:

Mechanical seal with a simple design for general use.

DIMENSIONS CHART

Dimensions in mm

Shaft		Rotary part			Stationary part		Total length
(")	mm	d ₃	d ₄	l ₃	d ₇	l ₄	l ₁
	12.00	23.30	28.30	16.30	24	4.5	20.8
	14.00	30.40	35.40	18.60	30	8.5	27.1
3/4	19.05	33.00	38.0	17.70	35	10.3	28.0
1	25.40	39.40	44.40	20.70	41.3	11.0	31.7

Dimensions subject to changes or modifications.

MSERB17 -MSERB17A - MSERB17E - MSERB17KU -LRB17NU

SECTORS:



CHARACTERISTICS:

- Unbalanced.
- Not dependent on the rotation direction.
- Single cylindrical spring.

OPERATING LIMITS:

$d_1 = 10 \div 100 \text{ mm}$ $p = 12 \text{ kg/cm}^2$
 $v = 10 \text{ m/s}$ $t = -15 \div +200 \text{ }^\circ\text{C}^{(*)}$

(*) The temperature resistance depends on the material of the secondary seals used.

The operating limits are defined by the PV factor which is determined for the sealing system characteristics and those of the application.

DESCRIPTION:

A versatile, robust single seal that is widely used in many different industrial and household applications.

The different typeMSERB17varieties can be combined with a wide range of stationary parts, thereby increasing its versatility due to the combination of different materials and working lengths.

Types:
 MSERB17KU-L6 / MSERB17KU-L60 : standardised dimensions in accordance with standard EN 12756 (KU).
 MSERB17NU -L6 / MSERB17NU-L60: standardised dimensions in accordance with standard EN 12756 (NU).

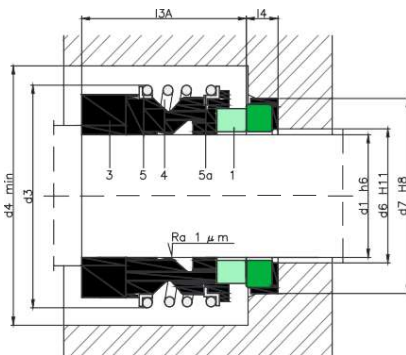

TYPE LRB17A

COMPONENTS:

- 1 Rotating contact surface
- 3 Bellows
- 4 Spring
- 5 Ring
- 5a Ring

DIMENSIONS CHARACTERISTICS

Dimensions in mm

Shaft	Rotary part				Stationary part		
	mm	d ₁	d ₃	d ₄	l _{3A}	d ₆	d ₇
15	15	28	33	17	29	35	4
20	20	37	42	21.5	29	35	7.5
25	25	41	46	23	34	40	7.5
30	30	48	53	24	45	51	9.5
45	45	65	70	30	58	65	12.5
55	55	80	85	43	67	76.5	14

Dimensions subject to changes or modifications.

DIMENSIONS CHART MSERB17 - MSERB17E - MSERB17KU- MSERB17NU

Dimensions in mm

Shaft mm	Rotary part						Stationary part																					
	d ₃	d ₄	l ₃	l _{3E}	l _{3KU}	l _{3NU}	d ₆	d ₇	d ₈	d ₁₁	d ₁₂	d ₁₄	d ₁₆	l ₅	l ₆	l ₇	l ₈	l ₉	l ₁₀	l ₁₁	l ₁₂	l ₁₃	l ₁₄	l ₁₅	l ₁₆	l ₁₇	l ₂₈	l ₂₉
10	22.5	25.0	14.5	25	25.9	33.4	17	21	3	15.5	19.2	11.0	24.60	1.5	4	8.5	17.5	10.0	7.5	-	7.5	-	6.6	1.2	3.8	7.5	6.6	9.0
12	25.0	27.5	15.0	25	25.9	33.4	19	23	3	17.5	21.6	13.5	27.80	1.5	4	8.5	17.5	10.0	7.5	-	6.5	-	5.6	1.2	3.8	7.5	6.6	9.0
14	28.5	32.0	17.0	25	28.4	33.4	21	25	3	20.5	24.6	17.0	30.95	1.5	4	8.5	17.5	10.0	7.5	-	6.5	-	5.6	1.2	3.8	9.0	6.6	10.5
15	28.5	32.0	17.0	25	-	-	-	-	-	20.5	24.6	17.0	30.95	-	-	-	-	-	-	-	7.5	-	6.6	1.2	3.8	9.0	-	10.5
16	28.5	32.0	17.0	25	28.4	33.4	23	27	3	22.0	28.0	17.0	30.95	1.5	4	8.5	17.5	10.0	7.5	-	8.5	-	7.5	1.5	5.0	9.0	6.6	10.5
18	32.0	34.5	19.5	25	30.0	37.5	27	33	3	24.0	30.0	20.0	34.15	2.0	5	9.0	19.5	11.5	8.5	12.5	9.0	10.0	8.0	1.5	5.0	9.0	7.5	10.5
20	37.0	39.5	21.5	25	30.0	37.5	29	35	3	29.5	35.0	21.5	35.70	2.0	5	9.0	19.5	11.5	8.5	12.5	8.5	9.5	7.5	1.5	5.0	9.0	7.5	10.5
22	37.0	39.5	21.5	25	30.0	37.5	31	37	3	29.5	35.0	23.0	37.30	2.0	5	9.0	19.5	11.5	8.5	12.5	8.5	9.5	7.5	1.5	5.0	9.0	7.5	10.5
24	42.5	45.0	22.5	25	32.5	42.5	33	39	3	32.0	38.0	26.5	40.50	2.0	5	9.0	19.5	11.5	8.5	12.5	8.5	9.5	7.5	1.5	5.0	9.0	7.5	10.5
25	42.5	45.0	23.0	25	32.5	42.5	34	40	3	32.0	38.0	26.5	40.50	2.0	5	9.0	19.5	11.5	8.5	12.5	8.5	9.5	7.5	1.5	5.0	9.0	7.5	10.5
28	49.0	51.5	26.5	33	35.0	42.5	37	43	3	36.0	42.0	29.5	47.65	2.0	5	9.0	19.5	11.5	8.5	14.0	10.0	11.0	9.0	1.5	5.0	10.5	7.5	12.0
30	49.0	51.5	26.5	33	35.0	42.5	39	45	3	39.2	45.0	32.5	50.80	2.0	5	9.0	19.5	11.5	8.5	14.0	11.5	11.0	10.5	1.5	5.0	10.5	7.5	12.0
32	53.5	56.0	27.5	33	35.0	47.5	42	48	3	42.2	48.0	32.5	50.80	2.0	5	9.0	19.5	11.5	8.5	14.0	11.5	11.0	10.5	1.5	5.0	10.5	7.5	12.0
33	53.5	56.0	27.5	33	35.0	47.5	42	48	3	44.2	50.0	36.5	54.00	2.0	5	9.0	19.5	11.5	8.5	14.5	12.0	11.5	11.0	1.5	5.0	10.5	7.5	12.0
35	57.0	59.5	28.5	33	35.0	47.5	44	50	3	46.2	52.0	36.5	54.00	2.0	5	9.0	19.5	11.5	8.5	14.5	12.0	11.5	11.0	1.5	5.0	10.5	7.5	12.0
38	59.0	61.5	30.0	33	36.0	46.0	49	56	4	49.2	55.0	39.5	57.15	2.0	6	9.0	22.0	14.0	10.0	14.5	11.3	11.5	10.3	1.5	5.0	10.5	9.0	12.0
40	62.0	64.5	30.0	33	36.0	46.0	51	58	4	52.2	58.0	42.5	60.35	2.0	6	9.0	22.0	14.0	10.0	14.5	11.8	11.5	10.8	1.5	5.0	10.5	9.0	12.0
43	65.5	68.0	30.0	41	36.0	51.0	54	61	4	53.3	62.0	46.0	63.50	2.0	6	9.0	22.0	14.0	10.0	17.0	13.2	14.3	12.0	2.0	6.0	10.5	9.0	12.0
45	68.0	70.5	30.0	41	36.0	51.0	56	63	4	55.3	64.0	46.0	63.50	2.0	6	9.0	22.0	14.0	10.0	17.0	12.8	14.3	11.6	2.0	6.0	10.5	9.0	12.0
48	70.5	73.0	30.5	41	36.0	51.0	59	66	4	59.7	68.4	49.0	66.70	2.0	6	9.0	22.0	14.0	10.0	17.0	12.8	14.3	11.6	2.0	6.0	10.5	9.0	12.0
50	74.0	74.5	30.5	41	38.0	50.5	62	70	4	60.8	69.3	52.0	69.85	2.5	6	9.0	23.0	15.0	10.5	17.0	12.8	14.3	11.6	2.0	6.0	12.0	9.5	13.5
53	78.5	82.5	33.0	41	36.5	59.0	65	73	4	63.8	72.3	55.5	73.05	2.5	6	9.0	23.0	15.0	12.0	17.0	13.5	14.3	12.3	2.0	6.0	12.0	11.0	13.5
55	81.0	85.5	35.0	41	36.5	59.0	67	75	4	66.5	75.4	58.5	76.20	2.5	6	9.0	23.0	15.0	12.0	18.0	14.5	15.3	13.3	2.0	6.0	12.0	11.0	13.5
58	85.5	89.5	37.0	41	41.5	59.0	70	78	4	69.5	78.4	61.5	79.40	2.5	6	9.0	23.0	15.0	12.0	18.0	14.5	15.3	13.3	2.0	6.0	12.0	11.0	13.5
60	85.5	92.5	38.0	41	41.5	59.0	72	80	4	71.5	80.4	61.5	79.40	2.5	6	9.0	23.0	15.0	12.0	18.0	14.5	15.3	13.3	2.0	6.0	12.0	11.0	13.5
65	93.5	97.5	40.0	49	41.5	69.0	77	85	4	76.5	85.4	68.0	92.10	2.5	6	9.0	23.0	15.0	12.0	18.0	14.2	15.3	13.0	2.0	6.0	14.5	11.0	16.0
68	96.5	100.5	40.0	49	41.2	68.7	81	90	4	82.7	91.5	71.0	95.25	2.5	7	9.0	26.2	18.0	12.5	19.0	14.9	16.0	13.7	2.0	6.0	14.5	11.3	16.0
70	99.5	103.5	40.0	49	48.7	68.7	83	92	4	83.0	92.0	71.0	95.25	2.5	7	9.0	26.2	18.0	12.5	18.0	14.2	15.3	13.0	2.0	6.0	14.5	11.3	16.0
75	107.0	111.0	40.0	52	48.7	68.7	88	97	4	90.2	99.0	77.5	101.60	2.5	7	9.0	26.2	18.0	12.5	18.0	15.2	15.3	14.0	2.0	6.0	14.5	11.3	16.0
80	112.0	116.0	40.0	56	48.0	78.0	95	105	4	95.2	104.0	84.0	114.30	3.0	7	9.0	26.2	18.2	13.0	19.0	16.2	16.3	15.0	2.0	6.0	18.5	12.0	20.0
85	120.0	124.0	41.0	56	46.0	76.0	100	110	4	100.2	109.0	87.0	117.50	3.0	7	9.0	26.2	18.2	15.0	19.0	16.0	16.3	14.8	2.0	6.0	18.5	14.0	20.0
90	127.0	131.0	45.0	59	51.0	76.0	105	115	4	105.2	114.0	93.5	123.85	3.0	7	9.0	26.2	18.2	15.0	19.0	16.0	16.3	14.8	2.0	6.0	18.5	14.0	20.0
95	132.0	136.0	46.0	59	51.0	76.0	110	120	4	111.6	120.3	96.5	127.00	3.0	7	9.0	25.2	17.2	15.0	20.0	17.0	17.3	15.8	2.0	6.0	18.5	14.0	20.0
100	137.0	141.0	47.0	59	51.0	76.0	115	125	4	114.5	123.3	103.0	133.35	3.0	7	9.0	25.2	17.2	15.0	20.0	17.0	17.3	15.8	2.0	6.0	18.5	14.0	20.0

Dimensions subject to changes or modifications.

The usual stationary part types:

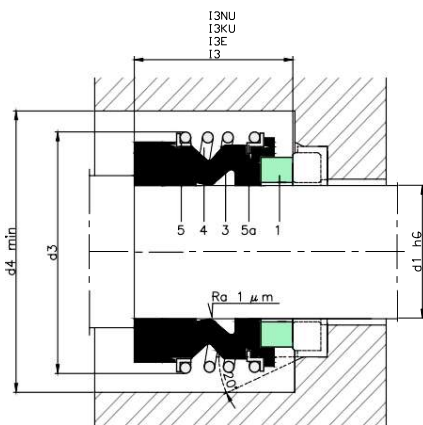

TYPE MSERB17 - TYPE MSERB17E - TYPE MSERB17KU - TYPE MSERB17NU

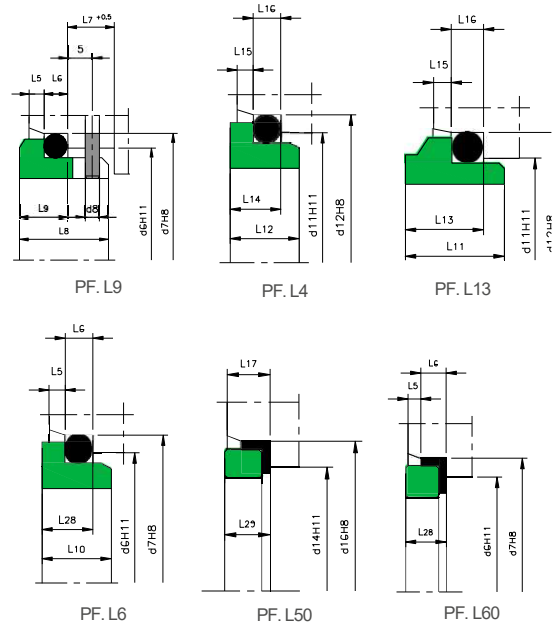

Tolerances l₁, d₁ 10... 12 mm ± 0.5; 14... 18 mm ± 1.0; 20... 25 mm ± 1.5; 28... 100 mm ± 2.0

MSERB25-R - MSERB25KU-R and MSERB25NU-R

SECTORS:



COMPONENTS:

- 1 Rotating contact surface
- 2 Stationary contact surface
- 3 Bellows
- 3a Elastomeric cup
- 4 Spring
- 5 Ring
- 5a Metal frame

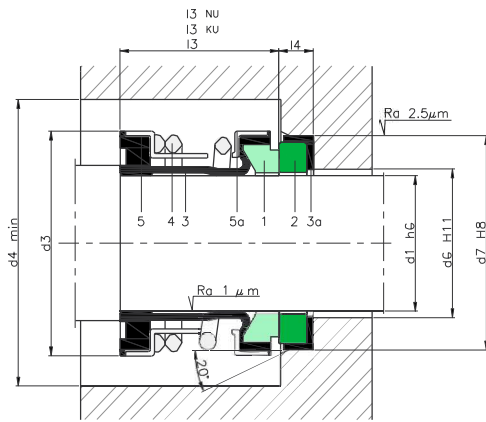

CHARACTERISTICS:

- **Balanced.**
- Not dependent on the rotation direction.
- **Single cylindrical spring.**

OPERATING LIMITS:

$d_1 = 10 \div 100 \text{ mm}$ $p = 20 \text{ kg/cm}^2$
 $v = 15 \text{ m/s}$ $t = -15 \div +200 \text{ }^\circ\text{C}^{(*)}$

(*) The temperature resistance depends on the material of the secondary seals used.

The operating limits are defined by the PV factor which is determined for the sealing system characteristics and those of the application.

DESCRIPTION:

An extremely versatile general-use mechanical seal. It has metal tabs that reduce fatigue and tension in the rubber bellows when in the working position. A balanced seal without the need for a stepped shaft. The seal can operate in applications with high pressures without suffering premature wear.

Types:
 MSERB25KU-R and MSERB25NU-R: standardised dimensions in accordance with standard EN 12756 (KU and NU respectively).

DIMENSIONS CHART

Dimensions in mm

Shaft mm	Rotary part					Stationary part		
	d ₃	d ₄	l ₃	l _{3KU}	l _{3NU}	d ₆	d ₇	l ₄
10	20	22	15	27.5	35.0	15	21	5.0
12	22	24	15	26.5	34.0	17	23	6.0
14	24	26	15	29.0	34.0	19	25	6.0
15	25	27	15	29.0	34.0	20	26	6.0
16	26	28	15	29.0	34.0	23	27	6.0
18	32	34	20	31.5	39.0	25	33	6.0
20	34	36	20	31.5	39.0	27	35	6.0
22	36	38	20	31.5	39.0	29	37	6.0
24	38	40	20	34.0	44.0	31	39	6.0
25	39	41	20	34.0	44.0	32	40	6.0
28	42	44	26	36.5	44.0	35	43	6.0
30	44	46	26	35.5	43.0	37	45	7.0
32	46	48	26	35.5	48.0	40	48	7.0
33	47	49	26	35.5	48.0	40	48	7.0
35	49	51	26	34.5	47.0	42	50	8.0
38	54	58	30	37.0	47.0	47	56	8.0
40	56	60	30	37.0	47.0	49	58	8.0
43	59	63	30	37.0	52.0	52	61	8.0
45	61	65	30	37.0	52.0	54	63	8.0
48	64	68	30	35.0	50.0	57	66	10.0
50	66	70	30	37.5	50.0	60	70	10.0
53	69	73	30	37.5	50.0	63	73	10.0
55	71	75	30	37.5	50.0	65	75	10.0
58	78	83	33	42.5	60.0	68	78	10.0
60	80	85	33	40.5	58.0	70	80	12.0
63	83	88	33	40.5	58.0	73	83	12.0
65	85	90	33	40.5	68.0	75	85	12.0
68	88	93	33	40.5	68.0	79	90	12.0
70	90	95	33	48.0	68.0	81	92	12.0
75	99	104	40	48.0	68.0	86	97	12.0
80	104	109	40	47.5	77.5	89	100	12.0
85	109	114	40	47.5	77.5	97	110	12.5
90	114	119	40	52.5	77.5	102	115	12.5
95	119	124	40	52.5	77.5	117	120	12.5
100	124	129	40	52.5	77.5	122	125	12.5

Dimensions subject to changes or modifications.

Dimensions in inches

Shaft (")	Rotary part					Stationary part		
	mm	d ₃	d ₄	l ₃	d ₇	l ₄		
0,375	9,53	20	22	15	22,23	7,9		
0,500	12,70	24	26	15	25,40	7,9		
0,625	15,88	26	28	15	31,75	10,3		
0,750	19,05	32	34	20	34,93	10,3		
0,875	22,23	36	38	20	38,10	10,3		
1,000	25,40	39	41	20	41,28	11,1		
1,125	28,58	42	44	26	44,45	11,1		
1,250	31,75	46	48	26	47,63	11,1		
1,375	34,93	49	51	26	50,80	11,1		
1,500	38,10	54	58	30	53,98	11,1		
1,625	41,28	56	60	30	60,33	12,7		
1,750	44,45	61	65	30	63,50	12,7		
1,875	47,63	64	68	30	66,68	12,7		
2,000	50,80	66	70	30	69,85	12,7		
2,125	53,98	69	73	30	76,20	14,3		
2,250	57,15	78	83	33	79,38	14,3		
2,375	60,33	80	85	33	82,55	14,3		
2,500	63,50	83	88	33	85,73	14,3		
2,625	66,68	88	93	33	85,73	15,9		
2,750	69,85	90	95	33	88,90	15,9		
2,875	73,03	96	101	33	95,25	15,9		
3,000	76,20	99	104	40	98,43	15,9		
3,125	79,38	103	108	40	101,60	19,8		
3,250	82,55	104	109	40	104,78	19,8		
3,375	85,73	108	114	40	107,95	19,8		
3,500	88,90	112	117	40	111,13	19,8		
3,625	92,08	114	119	40	114,30	19,8		
3,750	95,25	118	124	40	117,48	19,8		
3,875	98,43	122	127	40	120,65	19,8		
4,000	101,60	124	129	40	123,83	19,8		

AR / MSERB3 I



COMPONENTS:

- 1 Rotating contact surface
- 2 Stationary contact surface
- 3 Bellows.
- 3a Elastomeric cup
- 4 Spring
- 5 Ring
- 5a Blocking ring
- 5b Metal frame

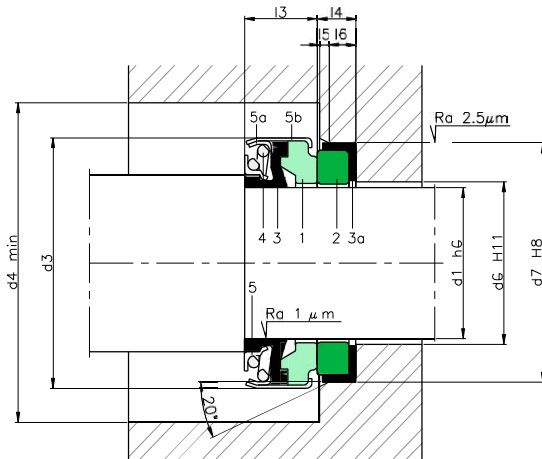

SECTORS:



CHARACTERISTICS:

- Unbalanced.
- Not dependent on the rotation direction.
- Single cylindrical spring.

OPERATING LIMITS:

$d_1 = 6 \div 70 \text{ mm}$ $p = 6 \text{ kg/cm}^2$

$v = 10 \text{ m/s}$ $t = -20 \div +140^\circ\text{C} (*)$

(*) The temperature resistance depends on the material of the secondary seals used.

The operating limits are defined by the PV factor which is determined for the sealing system characteristics and those of the application.

DESCRIPTION:

Economic mechanical seal with small dimensions, used in large household pump productions for recirculating water or for working conditions with low demands.

DIMENSIONS CHART

Dimensions in mm

Shaft mm	Rotary part				Stationary part				
	d ₃	d ₄	l ₃		d ₆	d ₇	l ₄	l ₅	l ₆
6	18	23	80	+0.5	8	22.0	4.0	0.5	3.5
6A	18	23	110	+0.5	8	22.0	4.0	0.5	3.5
8	20	23	110	+0.5	10	22.0	4.0	0.5	3.5
8A	20	27	110	+0.5	10	26.0	5.5	1.0	5.0
8B	24	27	110	+0.5	10	26.0	8.0	1.0	6.0
10	24	27	110	+0.5	12	26.0	8.0	1.0	6.0
11	24	27	110	+0.5	13	26.0	8.0	1.0	6.0
11A	24	27	130	+0.5	13	26.0	8.0	1.0	6.0
11B	24	27	110	+0.5	14	26.0	8.0	1.0	6.0
11R	24	27	128	+0.7	14	26.0	8.0	1.0	6.0
12C	24	27	130	+0.7	14	26.0	5.5	1.0	6.0
12	24	27	128	+0.7	15	26.0	8.0	1.0	6.0
13A	24	27	130	+0.7	15	26.0	5.5	1.0	6.0
14A	32	35	128	+0.7	16	29.5	8.0	1.0	6.0
14R	28	30	128	+0.7	18	28.5	7.5	1.0	5.5
14C	28	30	130	+0.7	18	28.5	8.0	1.0	5.5
15	32	35	128	+0.7	17	29.5	8.0	1.0	6.0
15A	28	35	130	+0.7	17	30.0	8.0	1.0	6.0
16A	32	35	128	+0.7	18	29.5	8.0	1.0	6.0
16B	39	43	128	+0.7	18	38.0	8.0	1.0	6.0
17	39	43	128	+0.7	19	42.0	8.0	1.0	6.0
18	39	43	128	+0.7	20	47.0	8.0	1.0	6.0
19	39	43	128	+0.7	21	47.0	8.0	1.0	6.0
20A	39	43	128	+0.7	22	42.0	8.0	1.0	6.0
20B	47	47	128	+0.7	22	45.0	10.0	1.0	8.0
22	47	47	128	+0.7	24	45.0	10.0	1.0	8.0
22A	39	47	130	+0.7	24	47.0	8.0	1.0	8.0
22	47	53	135	+1.0	25	50.0	10.0	1.0	8.0
24	47	53	135	+1.0	26	50.0	10.0	1.0	8.0
25A	47	53	135	+1.0	27	50.0	10.0	1.0	8.0
25B	47	53	135	+1.0	27	50.0	10.0	1.0	8.0
25C	47	53	130	+1.0	27	45.0	10.0	1.0	8.0
26	47	53	135	+1.0	29	50.0	10.0	1.0	8.0
27	47	53	135	+1.0	30	50.0	10.0	1.0	8.0
28	54	60	150	+1.0	31	57.0	10.0	1.0	8.0
30	54	60	150	+1.0	33	57.0	10.0	1.0	8.0
32	54	60	150	+1.0	35	57.0	10.0	1.0	8.0
35	60	70	160	+1.0	38	63.0	10.0	1.0	8.0
38	65	75	180	+1.0	41	68.0	12.0	2.0	9.0
40	65	75	180	+1.0	43	68.0	12.0	2.0	9.0
45	70	80	200	+1.0	48	73.0	12.0	2.0	9.0
50	85	95	230	+1.0	53	88.0	15.0	2.0	12.0
55	85	95	230	+1.0	55	88.0	15.0	2.0	12.0
60	105	115	300	+1.0	63	110.0	15.0	2.0	12.0
65	105	115	300	+1.0	68	110.0	15.0	2.0	12.0
70	105	115	320	+1.0	73	110.0	15.0	2.0	12.0

Dimensions subject to changes or modifications.

LRB50



COMPONENTS:

- 1 Rotating contact surface
- 2 Stationary contact surface
- 3 Bellows
- 3a O-rings
- 4 Spring
- 5 Ring
- 5a Metal frame

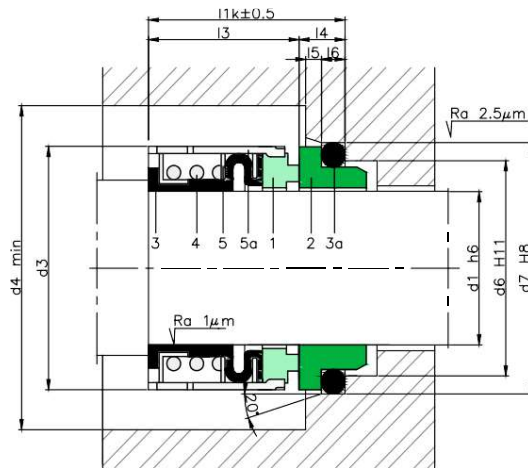

SECTORS:



CHARACTERISTICS:

- Balanced.
- Not dependent on the rotation direction.
- Single cylindrical spring.

OPERATING LIMITS:

$d_1 = 14 \text{ } +100\text{mm}$ $p = 20\text{kg/cm}^2$

$v = 15\text{m/s}$ $t = -15 \text{ } +200\text{ } (^{\circ}\text{C})$

(*) The temperature resistance depends on the material of the secondary seals used.

The operating limits are defined by the PV factor which is determined for the sealing system characteristics and those of the application.

DESCRIPTION:

A balanced seal without the need for a stepped shaft. The casing of the rotating part protects the bellows from abrasion and from the rotation transmission tensions, and the spring from blocking in the event of being contaminated by fibres and particles. It is recommended for use with highly viscous or sticky fluids containing fibres or particles, or with fluids that produce a chemical attack on the shaft.

DIMENSIONS CHART

Dimensions in mm

Shaft mm	Rotary part			Stationary part					Total length l_{1k}
	d_3	d_4	l_3	d_5	d_7	l_4	l_5	l_6	
14	24	26	23.0	21	25	12.0	1.5	4	35.0
16	26	28	23.0	23	27	12.0	1.5	4	35.0
18	32	34	24.0	27	33	13.5	2.0	4	37.5
20	34	36	24.0	29	35	13.5	2.0	5	37.5
22	36	38	24.0	31	37	13.5	2.0	5	37.5
24	38	40	26.7	33	39	13.5	2.0	5	40.2
25	39	41	27.0	34	40	13.0	2.0	5	40.0
28	42	44	30.0	37	43	12.5	2.0	5	42.5
30	44	46	30.5	39	45	12.0	2.0	5	42.5
32	46	48	30.5	42	48	12.0	2.0	5	42.5
33	47	49	30.5	42	48	12.0	2.0	5	42.5
35	49	51	30.5	44	50	12.0	2.0	5	42.5
38	54	58	32.0	49	56	13.0	2.0	6	45.0
40	56	60	32.0	51	58	13.0	2.0	6	45.0
43	59	63	32.0	54	61	13.0	2.0	6	45.0
45	61	65	32.0	56	63	13.0	2.0	6	45.0
48	64	68	32.0	59	66	13.0	2.0	6	45.0
50	66	70	34.0	62	70	13.5	2.5	6	47.5
53	69	73	34.0	65	73	13.5	2.5	6	47.5
55	71	75	34.0	67	75	13.5	2.5	6	47.5
58	78	83	39.0	70	78	13.5	2.5	6	52.5
60	80	85	39.0	72	80	13.5	2.5	6	52.5
63	83	88	39.0	75	83	13.5	2.5	6	52.5
65	85	90	39.0	77	85	13.5	2.5	6	52.5
68	88	93	39.0	81	90	13.5	2.5	7	52.5
70	90	95	45.5	83	92	14.5	2.5	7	60.0
75	95	104	45.5	88	97	14.5	2.5	7	60.0
80	104	109	45.0	95	105	14.5	2.5	7	60.0
85	109	114	45.0	100	110	14.5	2.5	7	60.0
90	110	119	50.0	105	115	15.0	3.0	7	65.0
95	119	124	50.0	110	120	15.0	3.0	7	65.0
100	124	129	50.0	115	125	15.0	3.0	7	65.0

Dimensions subject to changes or modifications.

MSETB 16



COMPONENTS:

- 1 Rotating contact surface
- 2 Stationary contact surface
- 3 Bellows
- 3a PTFE gasket
- 4 Spring
- 5 Ring
- 5a Set screw

SECTORS:



CHARACTERISTICS:

- Unbalanced.
- Not dependent on the rotation direction.
- External mounting.

OPERATING LIMITS:

$d_i = 25 \div 100 \text{ mm}$ $p = 12 \text{ kg/cm}^2$
 $v = 16 \text{ m/s}$ $t = -40 \div +200 \text{ }^\circ\text{C} (*)$

(*) The temperature resistance depends on the material of the secondary seals used.

The operating limits are defined by the PV factor which is determined for the sealing system characteristics and those of the application.

DESCRIPTION:

This mechanical seal model is mostly made of PTFE and other materials that are resistant to chemically aggressive products. The metal parts are isolated from the process fluid.

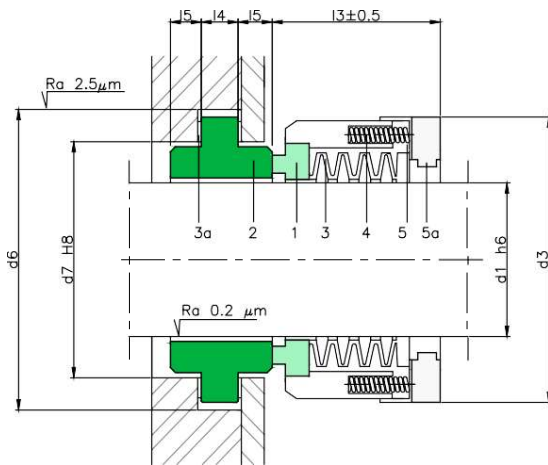

DIMENSIONS CHART

Dimensions in mm

Dimensions in inches

Shaft mm	Rotary part			Stationary part			
	d ₃	l ₃	d ₆	d ₇	l ₄	l ₅	
20	57	31	51	40.6	8	4.8	
25	61	33	54	42.86	8.0	4.8	
28	67	36	65	50.80	11.0	8.0	
30	70	37	68	53.98	11.0	8.0	
32	70	37	68	53.98	11.0	8.0	
33	73	38	71	57.15	11.0	8.0	
35	73	38	71	57.15	11.0	8.0	
38	76	38	78	63.50	11.0	8.0	
40	80	40	81	66.68	11.0	8.0	
43	83	40	84	69.85	11.0	8.0	
45	83	40	84	69.85	11.0	8.0	
48	89	43	97	79.38	14.3	9.5	
50	89	43	97	79.38	14.3	9.5	
53	103	53	100	82.55	14.3	9.5	
55	107	53	103	85.73	14.3	9.5	
58	110	53	106	88.90	14.3	9.5	
60	110	53	106	88.90	14.3	9.5	
63	113	53	110	92.08	14.3	9.5	
65	116	53	113	95.25	14.3	9.5	
68	118	53	116	98.43	14.3	9.5	
70	118	53	116	98.43	14.3	9.5	
75	126	53	121	103.19	14.3	9.5	
80	150	73	132	114.30	14.3	9.5	
85	156	73	138	120.65	14.3	9.5	
90	163	73	144	127.00	14.3	9.5	
95	163	73	144	127.00	14.3	9.5	
100	169	73	151	133.35	14.3	9.5	

Shaft (*)	Rotary part			Stationary part			
	mm	d ₃	l ₃	d ₆	d ₇	l ₄	l ₅
0,875	22,23	57	31	51	40,6	8	4,8
1,000	25,40	61	33	54	42,9	8	4,8
1,125	28,58	67	36	65	50,8	11	8
1,250	31,75	70	37	68	54	11	8
1,375	34,93	73	38	71	57,2	11	8
1,500	38,10	76	38	78	63,5	11	8
1,625	41,28	80	40	84	69,9	11	8
1,750	44,45	83	40	84	69,9	11	8
1,875	47,63	86	43	97	79,4	14,3	9,5
2,000	50,80	89	43	97	79,4	14,3	9,5
2,125	53,98	103	53	103	95,7	14,3	9,5
2,250	57,15	107	53	106	88,9	14,3	9,5
2,375	60,33	110	53	106	88,9	14,3	9,5
2,500	63,50	113	53	110	92,1	14,3	9,5
2,625	66,68	116	53	116	98,4	14,3	9,5
2,750	69,85	118	53	116	98,4	14,3	9,5
2,875	73,03	122	53	121	103,2	14,3	9,5
3,000	76,20	126	53	121	103,2	14,3	9,5
3,250	82,55	150	73	138	120,7	14,3	9,5
3,500	88,90	156	73	144	127	14,3	9,5
3,750	95,25	163	73	144	127	14,3	9,5
4,000	101,60	169	73	151	133,4	14,3	9,5

Dimensions subject to changes or modifications.

PNMSE



COMPONENTS:

- 1 Rotating contact surface
- 2 Stationary contact surface
- 3 Bellows
- 3a Elastomeric cup
- 4 Spring
- 5 Ring
- 5a Drive ring
- 5b Metal frame

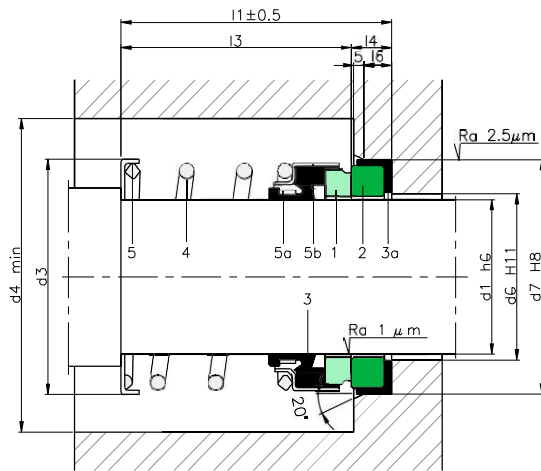

SECTORS:



CHARACTERISTICS:

- Unbalanced.
- Not dependent on the rotation direction.
- Single cylindrical spring.

OPERATING LIMITS:

$d_1 = 8 \pm 40 \text{ mm}$ $p = 12 \text{ kg/cm}^2$

$v = 10 \text{ m/s}$ $t = -20 \pm +120 \text{ }^\circ\text{C}^{(*)}$

(*) The temperature resistance depends on the material of the secondary seals used.

The operating limits are defined by the PV factor which is determined for the sealing system characteristics and those of the application.

DESCRIPTION:

Mechanical seal with a simple design for general use.

DIMENSIONS CHART

Dimensions in mm

Shaft mm	Rotary part			Stationary part					Total length l_1
	d_3	d_4	l_3	d_6	d_7	l_4	l_5	l_6	
8	22	27	15.5	14	26.00	5.5	0.5	4.5	21.0
10	22	27	15.5	14	26.00	5.5	0.5	4.5	21.0
11	22	27	15.5	14	26.00	5.5	0.5	4.5	21.0
12	22	27	15.5	14	26.00	5.5	0.5	4.5	21.0
13A	28	33	18.0	17	29.50	8.0	1.0	6.0	26.0
13B	32	37	13.0	17	29.50	8.0	1.0	6.0	21.0
14B	28	33	18.0	17	29.50	8.0	1.0	6.0	26.0
14C	28	33	22.0	19	23.10	6.0	1.2	3.0	28.0
14A	32	37	13.0	17	29.50	8.0	1.0	6.0	21.0
15A	28	33	18.0	17	29.50	8.0	1.0	6.0	26.0
15B	32	37	13.0	17	29.50	8.0	1.0	6.0	21.0
16C	28	33	18.0	17	29.50	8.0	1.0	6.0	26.0
16F	28	33	23.0	21	26.90	7.0	1.5	4.0	30.0
16E	31	36	29.0	17	29.50	8.0	1.0	6.0	37.0
16A	32	37	13.0	17	29.50	8.0	1.0	6.0	21.0
16D	32	37	13.0	17	42.00	8.0	1.0	6.0	21.0
16B	33	38	16.3	17	29.50	8.0	1.0	6.0	24.0
18A	32	37	24.0	20	42.00	8.0	1.0	6.0	32.0
18B	32	37	24.0	25	30.90	8.0	1.5	4.0	32.0
19.05	32	37	19.0	22	35.00	10.2	1.2	7.8	24.0
19.05	32	37	22.0	22	35.00	10.2	1.2	7.8	32.2
20A	32	37	22.0	22	42.00	8.0	1.0	6.0	30.0
20B	44	49	14.0	22	42.00	8.0	1.0	6.0	22.0
22A	39	44	25.0	30	35.40	8.0	2.0	4.0	33.0
22	44	49	14.0	23	42.00	8.0	1.0	6.0	22.0
25.4	42	47	27.2	29	41.25	11.0	1.5	8.5	38.2
30B	52	57	28.0	33	52.00	12.0	1.5	8.5	40.0
30A	60	65	22.0	33	52.00	12.0	1.5	8.5	34.0
31.75	52	57	49.2	34	47.62	11.0	1.5	8.5	60.2
40	63	68	35.0	45	68.00	12.0	1.5	8.5	47.0

Dimensions subject to changes or modifications.